

New Bern Amateur Radio Club



foto by W2RLG & W2HVX

Volume 32, Issue 11, November, 2009



Logo tnx to Eve, XYL of W2HVX

W4EWN/R

146.610 / 146.010 PL 100 Hz.

444.900 / 449.900 PL 100 Hz.

Website: <http://www.nbarc.org>

Next Meeting -- Thursday, November 5, 2009

6:20 PM at The Courtyards at Berne Village, 2701 Amhurst Blvd. see below for directions

Program: Club officer election meeting. Also a short talk on the TOM TOM GPS system as used in vehicles.

FINANCIAL REPORT

We have in Savings \$2,461.90. We have in our savings account \$756.27. The expenses for the month are Embarq \$29.97, Progress Energy \$32.76, Annual Equip Insurance \$180.00. We made a deposit of \$20.00 that Lyle Lewis gave us for 2010 membership. Our total equipment value has nearly doubled over the past ten years and the coverage has never been increased to cover the true value. Thanks to Sid WA4VBC, we have a fairly accurate master list of equipment, including the communication trailer. This list has been forwarded to the insurance co., and we are standing by for an updated annual cost. The \$180 will be deducted from that amount.

Ray Hemphill, W7OPH, Treasurer

President's Corner

We will meet at the Bern Village Court Yards dining room for the November 5th meeting. This is a trial meeting place to see how everyone likes it. If it does not work out, we will go back to Famous Pizza & Subs. We need to be there about 6:20 - 6:30 for dinner

and the meeting will start around 7:00. We can adjust the meeting start time as necessary. I will try not to allow the meeting to last past 8:00 so our total meeting time will not be changed. The only difference will be that those who came at 5:30 before will have to wait to 6:30 to eat. The meal is \$7.00, very reasonable, and the room is large, very nice, and we will have it to ourselves.

Directions are as follows:

- 1) From HWY 70 west, take the Glenburnie Rd. exit, then turn right onto Glenburnie Road.
- 2) Take the next right onto Amhurst Road (Next to the Fuel Warehouse).
- 3) Follow Amhurst Road about 200 yards and take the 2nd entrance to the Court Yards.
- 4) Enter the building with the fountain in front and the protected walkway into the building.

November is our annual club officer election meeting. Bruce, N8UTY, is the Nominating Committee Chairman and we will be voting on Club Officers and discuss other billets that need to be filled. So please think about what you can do to support our fine club.

The Club Auction will be moved back to after the 1st of the year. That will give us more time to gather all our

valuable electronic equipment that we want to get rid of. Proceeds from any sales will be donated to the club. Thanks to Howard, **KG4MBD**, Bob **KJ4HJH**, Ed, **W2YPM**, and all others who helped out with the ham radio display set up at the Bern Village Courtyards. There was a very good turnout for such short notice. Maybe we could put that on our list of annual activities. Thanks to all for your support.

73's Dave, **K4DJW**

Minutes of Meeting

NEW BERN AMATEUR RADIO CLUB

1 October 2009

The regular monthly meeting of the New Bern Amateur Radio Club was held this date and the meeting was called to order at 6:30 by President Dave Warwick **K4DJW**. There were 31 names on the roster, one of which is attached to these minutes.

Introductions were made from the floor. Dave made a few announcements and appointed an Election Committee. The committee will consist of Bruce Arnold, **N8UTY**, Bill Ash, **N2GAH**, and Bill Reasons, **KI4TDY**.

Bruce Arnold, **N8UTY**, spoke about the **MS 150**. They had about 25 hams, half from our club and half from the Raleigh Club. There were about 2500 riders which was an outstanding turnout. The MS Chapter President was very impressed with the support from the two clubs.

Howard Barrett, **KG4MBD**, will be heading up a fall festival at Bern Village. He will need volunteers and radio equipment for Saturday.

Bill Sanford, **K4VHO**, is working on an Injured Marine Fund Raiser. He will be selling tickets through the Leatherneck Motorcycle Club. Let's help him out.

Ed Valentine, **W2YPM**, gave a presentation on 2 meter sideband. There are many sites to help out with beacons and the QRZ website gives location and distance. If there is enough interest there might even be a 2 meter sideband net. Ed will be happy to help with any other information you may need. He passed out a lot of information to the club. You will also find vhf/uhf beacons on WZ1V. Thanks Ed.

Tom Hill, **KJ4IV**, announced that the next VE session will be 17, October.

The Maysville Hamfest will be 11 October. Show up early and get lots of raffle tickets and some great deals.

Motion to adjourn at 7:35

Robert Melle, **KJ4HJH**, Secretary

2

Courtyards Demonstration

The **NBARC** Ham Radio demonstration for residents of The Courtyards at Berne Village on Saturday, October 3, became a successful mini-Field Day. Club members on very short notice turned out to quickly go battery powered on the air to make HF and VHF contacts on fone and CW.

Responding members were: Bob M, **KJ4HJH**, who provided many of the needs, from comfy chairs to cold drinks to backup batteries to a 150 ft inverted V antenna; Bob G, **WB1CCY**, who anchored the VHF effort, then went on HF to contact the USCG net in CA. Brian, **KD4FUN**, initiated the first HF contact with an emergency exercise net here in The Old North State. Al, **W8UT** worked CW on 40m, chatting with Jim, **WB8NNJ** in OH. Jim, **KS4O**, patiently introduced a young high school student to the magic of personally operating, not just listening to, radio. The lad looked star struck, and indicated much interest in the CW operation. Pete, **KA4SXX**, provided the much needed club tables, and support also came with visits by Ed, **W2YPM**, and Ken, **K4KDM**.

Special mention goes to any club member who maintains and stores club property at their home. In this instance my heartfelt thanks are extended to Bob, **KJ4HJH**, and Pete, **KA4SXX**. Without these two we would have sat on the grass, thirsty, with our radios beside us, in order to brush off the occasional ant or grass hopper, and used a nearby clothesline for an antenna.

73, Howard, **KG4MBD**

DX on 2 Meters? "Tropo"

Last month Ed, **W2YPM**, gave a presentation on his project of getting back on 2 meters, and "weak signal" work. He has since gotten his beam up and made several contacts at distances up to 600 miles. He's planning to get the beams for 2m & for 70cm up a bit higher soon.

Al, **W8UT**, has also gotten his 2m beam up since, tho' hasn't made notable contacts other than with Ed. Both stations are running approx. 150 watts output.

Al has an older beam, a 7 element long Quagi, available free of charge to any club member who will use it to get on 2 meter SSB or CW. It requires a minimum of work to make it perfectly usable.

Quagis are an easily made, see QST magazine in April, 1977. For more Quagi info go to <http://www.arrl.org>, or contact Al, **W8UT** (he's made about 6 Quagis for VHF/UHF)

The Courtyards at The Berne Village -- Crafts Fair, October 3, 2009



The overall setup at The Berne Village's Craft Fair



Courtyards resident Everett Klipp, Jim, **KS4O**, Howard, **KG4MBD**



Bob M, **KJ4HJH**, Bob G, **WB1CCY**, Brian, **KD4FUN**, Ken, **K4KDM**, trying to figure out the menu on the rig



Al, **W8UT**, at the Vibroplex, on 40 meter CW

MOBILE RADIO ANTENNA-NOTES

By Sid Purvis, **WA4VBC**

The following is something most hams already know so it will only be a refresher and something to consider when purchasing or installing a new mobile antenna for 2 meters or 440 MHz. I ran across some field strength readings someone had made for those antennas in various positions on a vehicle. These match close, with a few exceptions, to what my personal experience has been over the years. In these tests, a base line was established with a permanent type antenna mount (hole in the roof) in the optimum position, the middle of the vehicle roof. This was the 0.0 Db reference point. Following are the reading for the various positions and antenna mount types:

Center of roof-permanent mount	= 0.0 Db.
Center of roof- Magnetic mount	= -0.2 Db.
Front of hood-Magnetic mount	= -2.4 Db.
Rear corner fender-Magnetic mount	= -3.4 Db.
Center of trunk- Magnetic mount	= -2.8 Db.
Rear trunk lip mount	= -2.8 Db.
Center of trunk-Permanent mount	= -2.1 Db.
Rear glass- on glass mount, high	= -0.5 Db
Rear glass-on glass mount, middle	= -1.2 Db
Back corner of roof-magnetic mount	= -3.4 Db.

Naturally, these readings will vary based on the position of the receiver relative to the vehicle orientation.

The center of the roof will provide an omni pattern where other than the center of the roof will provide a "skewed" pattern. I do not know the type of magnetic mount they were using as some are better than others. Also, keep in mind that some of the new vehicles have a type of glass and some with built in defroster wires or radio antennas in the glass that do not work well with the glass mount antennas. Some of the radio shops have "glass match tester" that will show if the glass will pass sufficient signal strength. In the past I have found that some of the cheaper ham type glass mounts, especially the dual band ones, can not be adjusted to get the SWR down to a good level.

If you want the very best (as the old Hallmark card ads used to say) go with a 3/4 " hole mount using a NMO type mount, sometimes referred to as the Motorola or New Motorola type mount. The 3/4" hole type is much stronger than the smaller ones and is the commercial standard. Check the rubber "o" rings on the mount and antenna base to be sure they are in good condition to prevent a water leak and apply a little silicone grease to the "o" rings when installing them.

Replacement "o" rings are available from various vendors such as Universal Radio.

(ed. note) Last month Sid referred to the NMO mount and included the following pic of the hole saw needed. Both he and Al, **W8UT**, have one of those saws, which are available to anyone who needs one.



Swap Shop

For Sale: Mosley Tri Band Beam, in pieces with clamps, some bolts, most if not all the coils and elements. Double wall boom. Massive and strong and heavy. It has been in my garage since we moved here. Reasonable.

Contact Ed Valentine, **W2YPM**, at 252-636-3161

Hamfests

Nov. 15 JARSFEST Benson, NC American Legion

605 North Wall Street <http://www.jars.net> Talk-In: 147.270 +600 Email: blambert1@mindspring.com

A 10 Meter Rotatable Dipole

Andy Griffith, **W4ULD**

This is an update of an article I wrote for the CCARS newsletter at the beginning of the last sun spot cycle.

The sunspots are coming back so it is time for everyone to get ready for the activity on 10 meters.. One can expect 10 meters to open frequently for worldwide communications. Sporadic E openings have already occurred allowing contacts to a wide range of the USA. High power is not needed on 10 meters, but a good antenna is important. So let's get some 10 meter antennas up and participate in the fun. I will talk about the 10 meter rotatable dipole.

Of course the best antenna for 10 meters is a beam because the signal (received and transmitted) is enhanced in the forward direction and significantly reduced off the back. Sometimes the reduced signal off the back can be most important by reducing QRM. However everyone is not able to have a beam. So how good is a dipole?

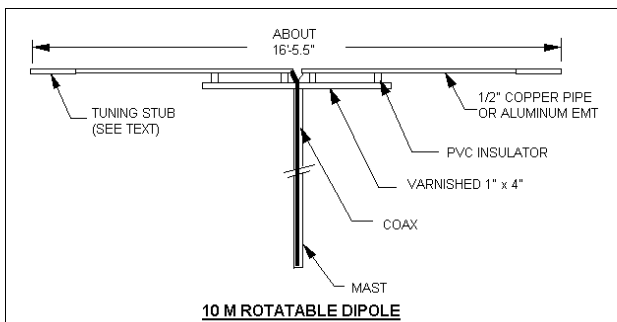

10 M ROTATABLE DIPOLE

Figure 1

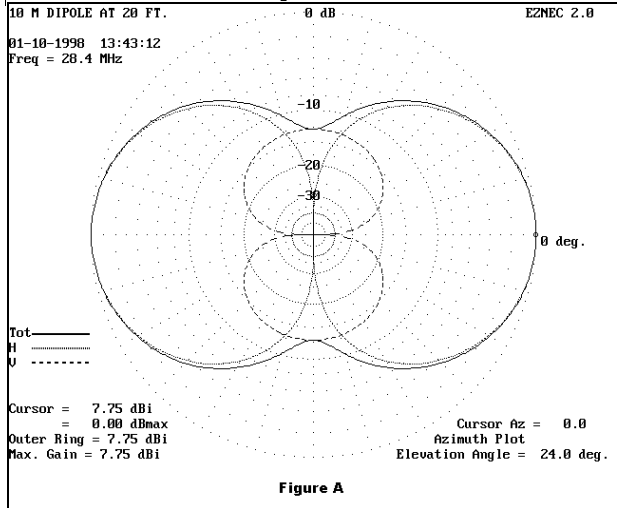

Figure A

As can be seen in Figure A and Figure B, the radiation from a 10 meter dipole even at 20 and 35 ft. height is more concentrated in the broadside lobes than dipoles at lower frequencies. Also the angle of radiation is lower (24 degrees at 20 ft. and 14 degrees at 35 ft.). Both factors are desirable for DX. However, off the ends of the dipole signals will be down 15 dB and 20 dB for heights of 20 ft. and 35 ft. respectively. Thus, one needs a bunch of dipoles to cover the desired directions or needs a single rotatable dipole. Also by rotating the dipole, one can sometimes “notch down” an interfering signal by placing it off the end of the antenna.

The broadside gain of the vertical lobes of a rotatable dipole will always exceed the gain of a vertical even at low radiation angles. Figure 2 shows the maximum radiation from a vertical ground plane antenna vs. a broadside rotatable dipole. At 14 degrees elevation angle the maximum gain of the ground plane antenna is at least 6.5 dB down from the rotatable dipole.

There are many ways to construct a rotatable dipole. A common technique is roughly diagrammed in Figure 1. The element is made of nominal 1/2” copper water pipe (5/8” OD x 0.025” wall). To match the antenna to the desired center frequency a movable stub is attached to each end. A 6” length of 21/32” brass hobby tubing will fit the copper pipe. An alternative is to use a 10 ft. length of aluminum conduit and insert a

4 ft. length of 5/8” OD aluminum tubing in each end. The conduit should be slit with a hack saw for about 1” and hose clamps placed over the slit to clamp the end sections in place. The stand-off insulators can take many forms. A 1” or 1-1/2” PVC pipe cap will work well. Drill a hole through the cap side-to-side for the element to pass through. Drill a hole through the end of the pipe cap for a mounting screw and at least one additional hole to let water out. Screw the cap to the varnished 1” x 4” boom with the closed end down. The element is split in the center with a 1/2” wide gap. Solder the shield of the coax to one side of the gap and the center conductor to the other. Seal the coax with Scotchkote or other sealant. A balun should not be needed if the coax is dressed along the mast. The mast can be either wood or metal. One can use his ingenuity to devise a mount between the 1” x 4” boom and the mast. A TV rotator will handle the antenna easily or one can rotate the mast and antenna by hand.

The dipole as described above is quite broad. The SWR should be less than 1.7:1 from 28.1 to 29 MHz.

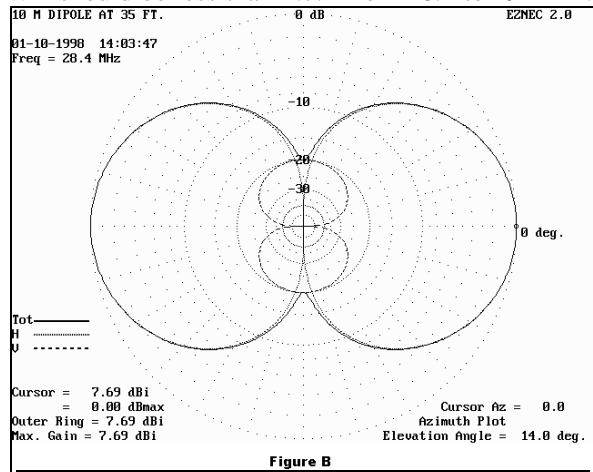
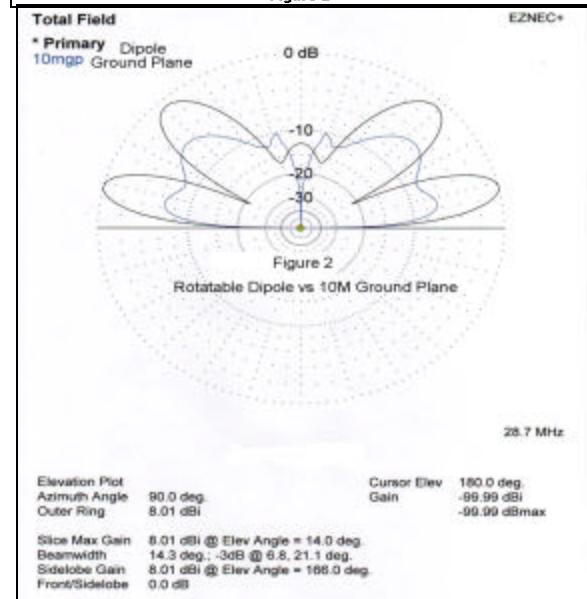

Figure B



Cast of Characters:

President: Dave Warwick, K4DJW
Vice President: Pete Koonce, KA4SXX
Secretary: Bob Melle, KJ4HJH
Treasurer: Ray Hemphill, W7OPH
Emergency Communications: Jim Wright, KS4O
Assistant Em. Comm.: Mark Rappaport, W2EAG
Public Svc/Special Events/VEC: Bruce Arnold, N8UTY
Repeater Trustee: Billy Morton, KE4YMA
Program Committee Chairman: Mack the Knife
Photography: Mac Eutsler, WA0ZGL

The Newsletter Team:

Al Parker, W8UT, Editor, Ray Hemphill, W7OPH, mailings
The NBARC Newsletter is the newsletter of the New Bern
Amateur Radio Club, Inc., 1508 Kimberly Road, New Bern,
NC 28562.. NBARC is an affiliated club with the ARRL and
ARES.

Material contained herein may be quoted, copied, folded,
torn, spindled, mutilated, etc., as long as proper credit is
given. Any inquiries, comments, items for Swap Shop,
suggestions, contributions, and letters for inclusion
should be sent to the Editor, W8UT, at e-mail:

anchor@EC.RR.COM

Selected Local Nets Times are local time, unless otherwise stated

Club Net Manager: position open
Craven County ARES: 146.61 MHz, 2000 before threatening
wx; monitor during ARES activations
NC ARES Net, 3.923 MHz, 19:30 daily
Waterway Radio Cruising Club: 7268 kHz, 0745 daily
Fairfield Harbor Cruising Net, 7224, 0730 M-F
NC Morning Net: 3927 kHz, 0745 daily
Carolina Slow Net (CW): 3695 kHz, at 8PM ET (5wpm) daily
Coastal Carolina Emergency Net: 3908 kHz, 1900 daily
Tarheel Emergency Net: 3923 kHz, 1930 daily
Carolinas Net (CW): 3573 kHz, 1900 (20 WPM), 2200 (10
WPM) daily
Carteret County ARS/ARES: 145.45 mHz, 1930 Tues./ Emerg
Traffic handling 1st Tues. after 4th Sat., monthly Skywarn:
145.21 mHz, 2100 Tuesdays
Pamlico County ARES: 147.210 MHz, tone 151.4, 1930 Wed.
ENC Emergency: 146.685 mHz, 2100 Thursdays
ENC Traffic: 146.685 mHz, 2030 daily
NBARC Ragchew: 146.61 mHz, 2000 daily

New Bern Amateur Radio Club

<http://www.nbarc.org>

1508 Kimberly Road, New Bern, NC 28562